

Installation instructions Rigid Core Planks



Floating installation of Rigid Core Planks with mechanical joint

Carefully read through the entire installation instructions before installing the floor.

Preparations

The temperature in the room and floor must be at between 18-25°C/64-77°F. Spread the boxes out to ensure they acclimatise properly.

Inspect each panel thoroughly before installation. If you have hired a professional, they should also read the entire installation instructions before starting the installation. Bjelin takes no responsibility for obvious defects or losses that could have been identified before the installation.

Open 2-3 packages to check for any differences in colour and design, and feel free to mix them. This will help you get an idea of the variation before installation.

The floor should be installed floating, meaning the panels are joined together without being attached to the subfloor. The floor should never be glued, nailed, or screwed to the underlying surface.

- The subfloor should be hard, dry, level, firm, and clean.
- Wall-to-wall carpets should be removed.
- Rigid Core Planks can be installed over underfloor heating, and any underfloor heating system should provide effective and even heat distribution across the floor. The surface temperature of the floor should never exceed 27 °C (80 °F) (this also applies to pipes for radiators and under any rugs, etc.).
- Check the flatness of the subfloor over a 2-metre (6') span and a 0.25-metre (12") span. If the irregularities exceed ± 3 mm over a 2-metre span or ± 1.2 mm over a 0.25-metre span, they must be leveled out. Deviations of up to ± 2 mm (1/4") over a 1-metre (3') span are acceptable.
- The room's relative humidity should be between 30% and 60%. In case of low humidity, you can increase it using a humidifier, and in case of high humidity, you can dehumidify using a dehumidifier.
- The subfloor should be dry and well cleaned to prevent mould. In most cases, this means vacuuming the subfloor.
- A moisture barrier is mandatory for subfloors that are newly cast, beam construction, lightweight concrete beams, concrete floors directly on the ground, crawl space foundations, on beam constructions above warm or damp areas (e.g., boiler rooms or laundry rooms), or over underfloor heating systems.
- Newly cast concrete floors should have a relative humidity below 90% at the time of installation.
- Rigid Core Planks comes with pre-attached underlayment foam. Rigid Core Planks should not be used in combination with other acoustic underlays.

- The panels will expand and contract with varying climate conditions, so there should be an expansion gap of at least 8-10 mm (1/4") towards walls and fixed objects (stairs, columns, door frames, etc.) to allow for easy and smooth installation. This expansion gap should be present around the entire perimeter of the floor, adjacent to walls and other fixed objects. Keep in mind that if even 10 mm (1/4") of your newly installed floor is in contact with another surface, such as a wall, the floor's ability to expand will be compromised. Rooms up to 25 metres wide (82') and 25 metres long (82') can be installed as a continuous surface. If the floor is larger, it should be divided. Floors should be divided at door openings with an expansion joint. Cover the expansion joint with a moulding. U-shaped rooms and at transitions to corridors, expansion joints should be installed.
- The baseboard or T-moulding should be 50% thicker than the width of the expansion joint. For example, if you have calculated that you need an 8 mm (1/4") expansion joint between the floor and the wall, the baseboard should be at least 12 mm (1/2") thick.

Installation

First, calculate the number of panels needed for the width of your room. If the last row of panels is narrower than 40 mm (1 1/2"), the first row should also be cut so that the starting and ending panels have the same width. This will result in a neater installation. Start with the long wall that has the most doors if applicable. If there are doors on the short side, start the row there. The panels can be installed from the left or right side, as well as in reverse.

Use spacers to create the proper gap between the floor and the wall. These will allow for an expansion gap of at least 8-10 mm (1/4") towards the wall and other fixed objects.

Finally, remove the spacers and cover the gap between the wall and the floor with a baseboard or moulding. A transition moulding or leveling moulding is used to join Rigid Core Planks with other flooring materials. Install mouldings in a way that allows the floor to move with climate and temperature variations.

Thickness of baseboard

- Remember that the floor's expansion joint determines the thickness of the baseboard, not the other way around.
- Larger floor areas require larger expansion joints, which means thicker baseboards.

Tip: *If you're renovating or building, a simple way to avoid thick baseboards is to raise the wall covering slightly higher, allowing the floor to move underneath. See image B.*

This is how you select the thickness of the baseboard

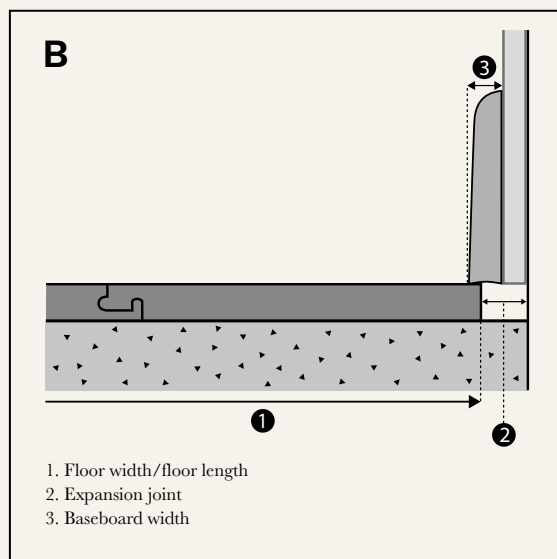
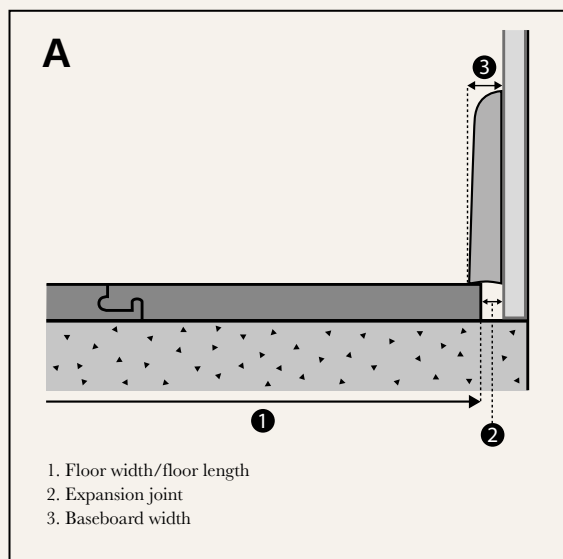

Ensure that the floor can move freely beneath the wall panels.

Minimum thickness of the expansion joint and baseboard for different floor widths

FLOOR WIDTH ①	EXPANSION JOINT* ②	BASEBOARD THICKNESS ③
5 m (16')	8 mm (1/4")	12 mm (1/2")
10 m (32')	8 mm (1/4")	12 mm (1/2")
15 m (49')	10 mm (1/4")	15 mm (3/4")
20 m (65')	12 mm (1/2")	18 mm (3/4")
25 m (82')	15 mm (3/4")	21 mm (1")

* For easy installation, the minimum recommended expansion joint is 8–10 mm.

Protective covering

The general rule is to install the floor last in the construction process to avoid damage. If additional work needs to be done in the room where the floor has been installed, the floor should be covered with a material that allows moisture to pass through (e.g., paper). Also, check that it does not discolour the floor or leave residues such as wax. Do not tape directly onto the floor, only onto the protective covering. Many tapes adhere so strongly to the floor surface

that it may cause the surface treatment to peel off when removing the tape. The longer the tape is left in place, the greater the risk that it will adhere more firmly to the surface treatment.

If you encounter a damaged panel, set it aside. It may be left over or can be used for finishing. Of course, you can replace it where you purchased it. The floor installer is responsible for not using panels with obvious defects.

Instructions

1

Start by removing or cutting off door casings/jambes so that the floor can slide underneath, resulting in a clean and professional finish. The easiest way is to use a multi-tool or a coping saw. Use an inverted board with padding as a template to ensure the correct height. Remember that the floor should not be locked against, or under, the door jamb.

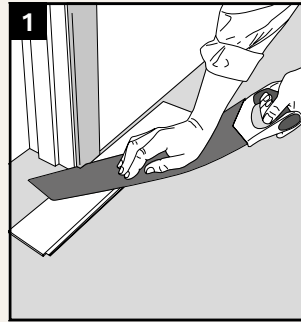

2

Start in the left corner and place the first panel with its bottom lip facing outward into the room on both the long and short sides. The distance between the long side and the wall can be adjusted later once three rows have been installed.

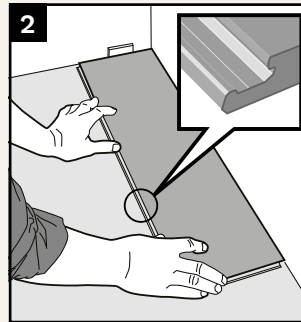

3

The next panel is placed with its short end against the short end of the first panel. Press down the short end until it clicks and locks into place. Continue in the same manner along the entire first row.

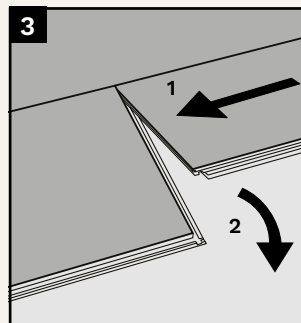

4

Trim the last panel in the first row to the correct length. Don't forget to leave an expansion joint around the perimeter of the floor.

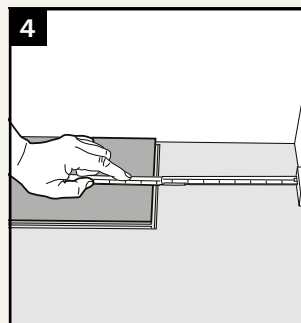

5

Start the next row with the leftover piece from the previous row. The end joints of the panels should be staggered by at least 300 mm (12").

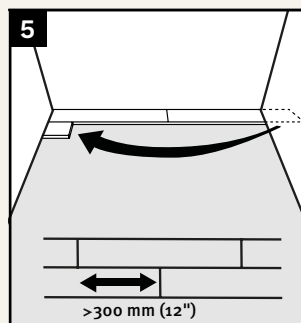

6

Press the long side of the new panel into the already laid panel to create a tight joint. Then, gently push the panel downward while lightly tapping it with your hand until it easily falls into place.

Be cautious while tapping them together to avoid any damage. Make sure there is no debris in the joint, as this can hinder or damage the panel if forced together. Continue laying the remaining rows in the same manner.

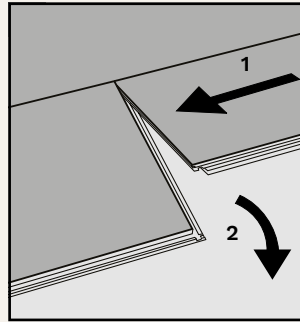

7

After three rows have been installed, you can adjust the distance of the floor to the walls. Place spacers between the floor and the walls. Once the floor is fully installed, remove the spacers.

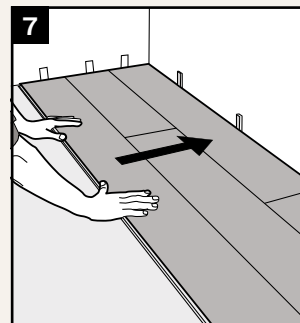

8

Sometimes, the first row of flooring needs to be adjusted to accommodate an uneven or curved wall. Trace the contour of the wall onto the panels. Then, release the panels in the first row by gripping the long side, pulling upward, and simultaneously lightly tapping the joint. Cut along your traced line. For optimal results, it may also be necessary to split the first panel so that the first and last rows are of equal size, avoiding a too small panel at the end.

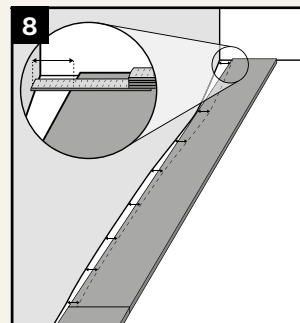

9

The final row: Measure the exact width of the last row. Here's how to do it: Place the last panel on top of the second-to-last row with approximately 8* mm (1/4") offset towards the wall. Mark the cutting point using a panel piece without the bottom lip. Install the cut panel. Sometimes, you may need to gently use a pry bar or crowbar to help bring down the final row if necessary.

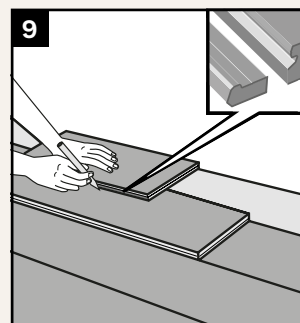

10

For pipes, drill holes in the panel that should be at least 20 mm larger in diameter than the pipe. Cut as shown in the images. Apply PVC adhesive, such as contact adhesive, to the joints on the cut piece and press it firmly. Remove any excess adhesive immediately. Place weights on the glued piece for at least 24 hours. Cover the holes with pipe sleeves.

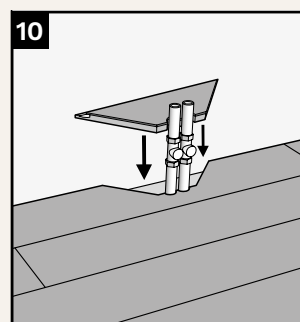

*See table page 3.

11

If you cannot angle the panel under, for example, door casings or jambs, follow these steps: Use a chisel or hand plane to cut or shave off the locking mechanism. Apply PVC adhesive, such as contact adhesive, to the bottom lip and place the panels. Use spacers to press the panel firmly while the adhesive dries.

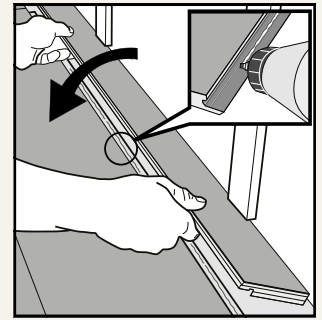
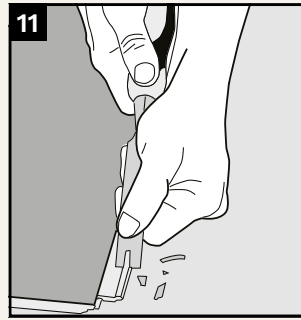

12

If you need to remove an already installed panel, the easiest way is to use Bjelin's dismantling pin. Insert this tool into the joint on the short side to release the locking mechanism on the short end. With this tool, you can remove individual panels without disassembling the entire row.

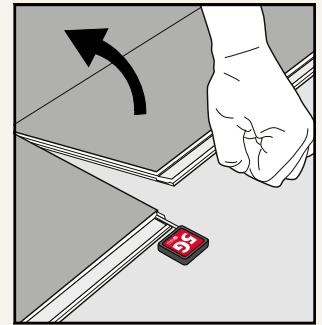
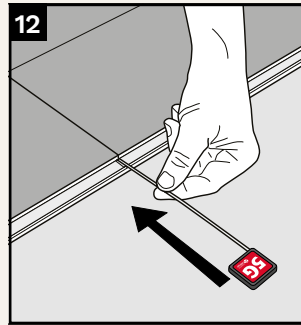

13

If you don't have this tool and need to remove a panel after installation, you can angle up an entire row of panels at a time along the long side. Disassemble the short ends by sliding them apart horizontally.

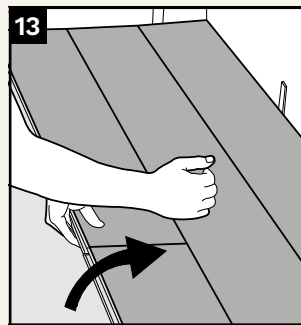

Reverse installation

1

When installing in reverse, you lay the panels from left to right. Angle the bottom lips under the previously installed row and press them down.

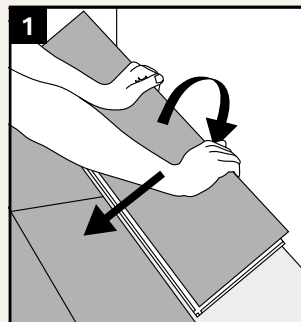

2

Angle the next panel under the installed row and slide them towards the short side of the adjacent panel, then press it down. Gently push down on the short end of the panel until you hear a click, indicating that it is locked in place.

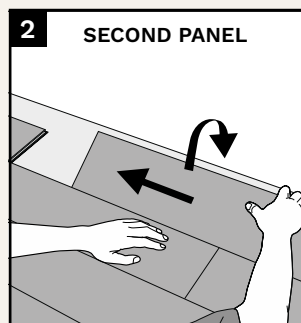

Maintenance and care of our floors

Rigid Core Planks are easy to maintain. Daily care is best done by vacuuming and occasionally damp mopping the floors with a well-wrung cloth. When damp mopping the floor, it should dry within 2–3 minutes, indicating that you have used the right amount of water.

Using excessive water can damage the floor.

If you accidentally spill something, it won't leave marks on your floor as long as you promptly wipe it up.

Place a doormat outside and inside the entrance door to prevent bringing in dirt and grit that can cause wear on your

floors. Therefore, be careful not to bring it onto your Bjelin floor, and it will last for many years to come.

Using felt pads is recommended to avoid unnecessary marks and scratches on the floor.

If you encounter a stain on the floor, refer to the table below.

Be cautious with strong stain removers. Using too much and excessive rubbing can affect the finish of your floor.

For more detailed maintenance instructions, visit bjelin.com/en/support/products/rigid-core

Stain key

STAINS FROM	REMOVED WITH
Asphalt, rubber, oil, shoe polish, soot, and dried residues of chocolate or grease	Bjelin Ecoline Magic Cleaner or Bona Kemi Deep Cleaner diluted in water or similar. Follow the instructions on the packaging
Crayons, lipstick, markers	Cleaning alcohol diluted 50/50 with water
Wax, chewing gum	Cooling spray or place a bag of ice cubes on the stain, then gently scrape
Blood	Bjelin Ecoline Wash Care or a neutral cleaning agent diluted in water. Follow the instructions on the packaging

For more information regarding maintenance, care, and repairs, please visit our website bjelin.com/en/support/products/rigid-core



Checklist:

- ✔ Remove all baseboards
- ✔ Remove or cut off door casings and jambs
- ✔ Ensure that the subfloor is hard, dry, level, stable, and clean
- ✔ Ensure that the room and panels have the correct temperature and humidity
- ✔ Leave proper expansion joints between the floor and all fixed objects such as walls, thresholds, columns, or pipes



Tools and equipment you will need:

- ✔ Safety glasses
- ✔ Approved dust mask
- ✔ Vacuum cleaner
- ✔ Spacers
- ✔ Saw
- ✔ Pen
- ✔ Measuring tools
- ✔ Square
- ✔ Optional vapour barrier
- ✔ PVC adhesive, such as contact adhesive



Share your stunning
new floors with us!
@bjelinflooring



BJELIN