

BJELIN

Woodura Furniture

SOLACE ROUND COFFEE TABLE

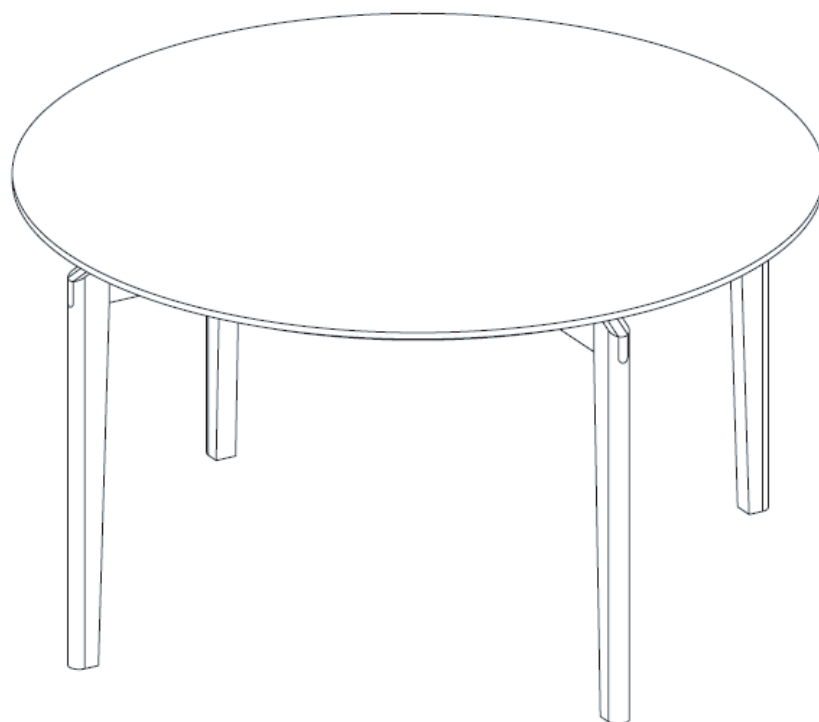

Read the product manual carefully before using your product.

If you do not follow the instructions, you risk damaging the product or, in the worst case, causing injury. Keep the product manual for future reference. If the product is later passed on to third parties, this manual must also be provided.

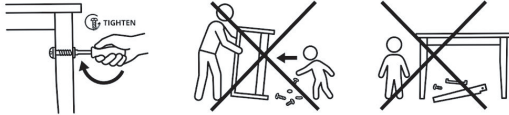

Please tighten the screws/legs after 4-5 weeks of use and then subsequently every 4-5 months.
 We do not recommend that young children are present during assembly due to small spare parts.
 Never leave your child unattended with a design that has not been fully assembled.



Keep packaging away from small children. Thin film may cling to the nose and mouth and prevent breathing.

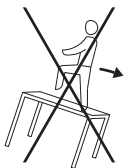

Do not use furniture as a climbing aid.

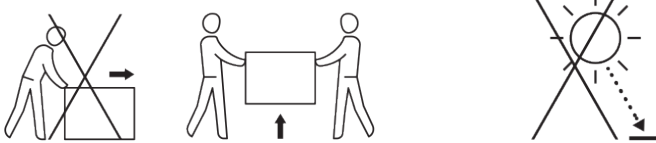

This product is only for indoor use.
 Do not push or drag the furniture across the floor - please lift when moving.
 Do not place the furniture in direct sunlight.

It is important to follow these care instructions to ensure proper maintenance of your new furniture.

Indoor climate

Wood is affected by relative humidity. It will expand in the summer and shrink in the winter. To avoid cracks and deformation, the relative humidity (RH) should be kept between 30–60%.

Assembly and handling

- Assemble the furniture on a soft surface to prevent scratches.
- Follow the assembly instructions carefully to avoid damage.

Avoid dirt, damage and sun bleaching – bear in mind

- Use coasters under glasses, vases and hot objects.
- Avoid placing wet or dirty objects directly on the surface.
- Use coasters or furniture pads under decorations and lamps.
- Avoid placing furniture in direct sunlight to reduce the risk of sun bleaching.
- Move table cloths, placemats and decorations occasionally to even colour changes in the wood.
- Protect against scratching – do not drag hard objects across the furniture.
- Do not place the furniture on a damp floor.
- Avoid putting candles, tape or stickers directly on the surface.
- Avoid placing the furniture near heat sources.
- Use furniture pads to protect the floor and the furniture.

Maintenance

- Regularly check that the legs, fittings and hinges are stable, and tighten screws and fittings as necessary.

Cleaning

Daily cleaning

- Wipe with a dry or damp microfibre cloth.
- If necessary, a cleaning agent like Bjelin Ecoline Wash Care Spray can be used.
- Only use as much liquid as will dry within 2–3 minutes.

Cleaning

Stain removal

- Wipe up any spills immediately, especially coloured liquids such as coffee, wine or juice.
- Avoid strong detergents – use a mild soap solution if necessary, such as Bjelin Ecoline Wash Care Spray.
- Apply the cleaner directly to the stain, leave for 2–3 minutes and wipe with a microfibre cloth.
- For tougher stains, use Bjelin Ecoline Magic Cleaner and follow the instructions carefully.

Periodic maintenance

After long-term use, the surface may lose some of its lustre. The following steps are recommended to bring the shine back.

1. Wipe with a dry or damp microfibre cloth. If necessary, a cleaning agent like Bjelin Ecoline Wash Care Spray can be used. Only use as much liquid as will dry within 2–3 minutes.
2. Apply Bjelin Ecoline Lacquer Refresher and follow the instructions carefully – test on a less visible area first.
3. Leave the surface to dry for at least 30 minutes.

Repairing surface damage

- Superficial scratches can be treated with Bjelin Touch-up paint and then with Bjelin Multitop Lacquer.
- Deeper damage can be filled with wood filler or melting wax of the right shade before treating the surface.
- Contact a professional to repair deeper scratches or damage.

Further information

Please go to www.bjelin.com or contact support@bjelin.com for further information on care and maintenance.

TOOLS, FITTINGS AND PRODUCT PARTS

A

M6x50 x 4

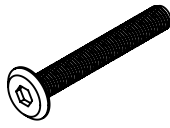

B

Assembly tool x 1

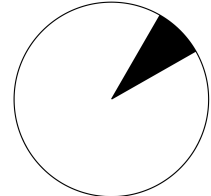
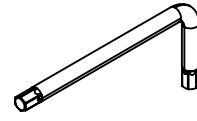

5-10 min
assembly time

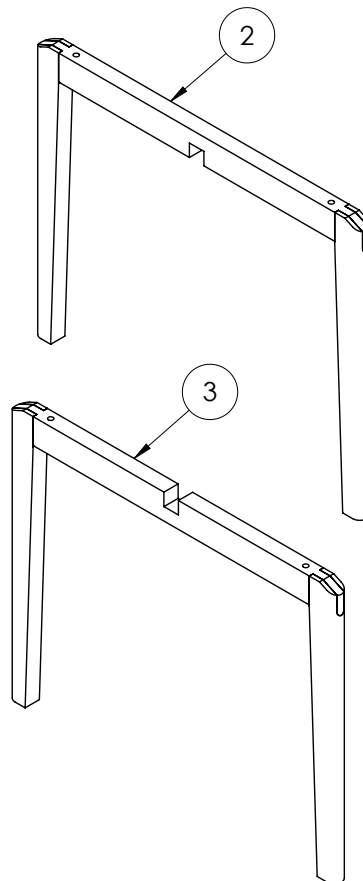
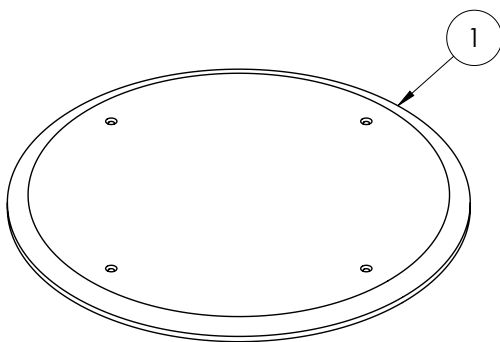
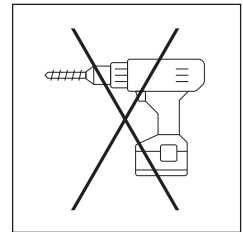

1	1x
2	1x
3	1x

ASSEMBLY - STEP 1

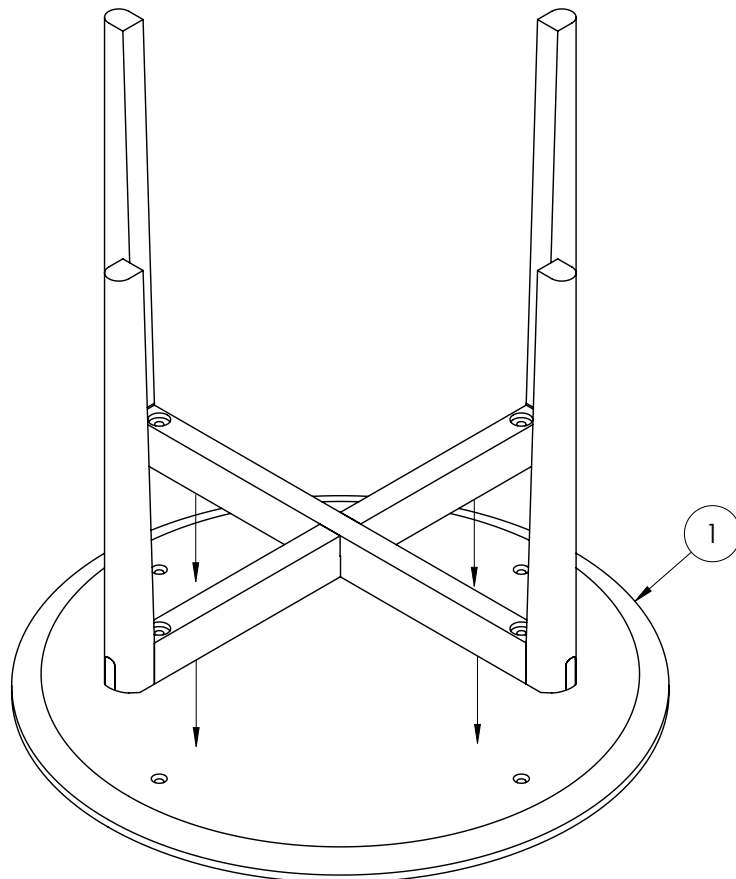
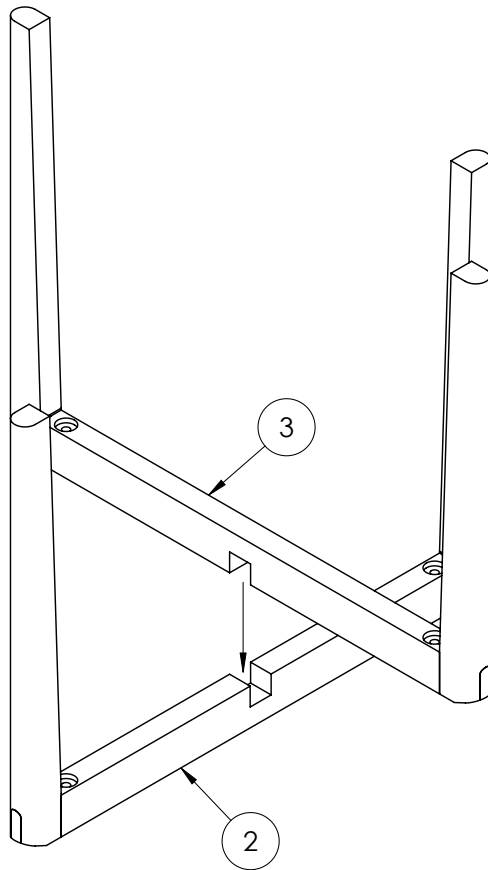

ASSEMBLY - STEP 2

